

MODEL	BF95-60
Standby Power (60Hz)	88KW / 110KVA
Prime Power (60Hz)	80KW / 100KVA

Standard Features

- General Features:
- Engine (BaiFa CA4DF2-14D)
 - Radiator 40°C max, fans are driven by belt, with safety guard
 - 12V charge alternator
 - Alternator: single bearing alternator IP23, insulation class H/H
 - Absorber
 - Dry type air filter, fuel filter, oil filter
 - Main line circuit breaker
 - Standard control panel
 - 12V batteries, rack and cable
 - Ripple flex exhaust pipe, exhaust siphon, flange, muffler
 - User manual

Generator Ratings

Voltage	HZ	Phase	P.F (COS ϕ)	Standby Amps	Standby Ratings (KW/KVA)	Prime Ratings (KW/KVA)
230/132	60	3	0.8	276	88/110	80/100

Prime Power (PRP): Prime power is available for an unlimited number of annual hours in variable load application, in accordance with GB/T2820-97 (eqv ISO8528) ; A 10% overload capability is available for a period of 1 hour within a 12-hour period of operation.

Standby Power Rating (ESP): The standby power rating is applicable for supplying emergency power for the duration of a utility power interruption. No overload, utility parallel or negotiated outage operation capability is available at this rating.

Sales Promises

Baifa Power provides a full line of brand new and high quality products. Each and every unit is strictly factory tested.

Warranty is according to our standard conditions: a, 15 months, counted on the day BAIFA sold to the first buyer; b, One year after installation; c, 1000 running hours (accumulated); subject to the earlier one.

Service and parts are available from Baifa Power or distributors in your location.

ENGINE DATA

Manufacturer / Model:	BaiFa CA4DF2-14D, 4-cycle
Air Intake System:	Turbocharged
Fuel System:	Direct injection
Cylinder Arrangement:	4 in line
Displacement:	4.75L
Bore and Stroke:	110×125 (mm)
Compression Ratio:	17
Rated RPM:	1800rpm
Max. Standby Power at Rated RPM:	110KW/150HP
Governor Type:	Electronic

Exhaust System

Exhaust Gas Flow:	19.1m ³ /min
Exhaust Temperature:	460°C
Max Back Pressure::	6.7kpa

Air Intake System

Burning Capacity:	7.5m ³ /min
Max intake restriction:	6.3kpa

Fuel System

100%(Prime Power) Load:	209g/kWh
75%(Prime Power) Load:	209g/kWh
50%(Prime Power) Load:	221g/kWh
100%(Prime Power) Load:	23.1L/h

Oil System

Total Oil Capacity:	14L
Oil Consumption:	0.08L/h

Cooling System

Max Water Temperature:	97 ±2°C
------------------------	---------

ALTERNATOR SPECIFICATION**GENERAL DATA**

Compliance with GB755, BS5000, VDE0530, NEMAMG1-22, IED34-1, CSA22.2 and AS1359 standards.

Alternator Data

Number of Phase:	3
Connecting Type:	3Phase and 4Wires, "Y" type connecting
Number of Bearing:	1
Power Factor:	0.8
Protection Grade:	IP23
Altitude:	≤1000m
Exciter Type:	Brushless, self-exciting
Insulation Class, Temperature Rise:	H/H
Telephone Influence Factor (TIF):	<50
THF:	<2%
Voltage Regulation, Steady State:	≤±1%
Alternator Capacity:	100KVA
Alternator Efficiencies:	90.9%

GENERATING SET DATA

Voltage Regulation:	≥±5%
Voltage Regulation, Stead State:	≤±1%
Sudden Voltage Warp (100% Sudden Reduce):	≤+25%
Sudden Voltage Warp (Sudden Increase):	≤-20%
Voltage Stable Time (100% Sudden Reduce):	≤6S
Voltage Stable Time (Sudden Increase)	≤6S
Frequency Regulation, Stead State:	≤5%
Frequency Waving:	≤1.5%
Sudden Frequency Warp (100% Sudden Reduce):	≤+12%
Sudden Frequency Warp (Sudden Increase):	≤-10%
Frequency Recovery Time (100% Sudden Reduce):	≤5S
Frequency Recovery Time (Sudden Increase):	≤5S

Standard Features

- ◇ Baifa Standard Auto Control System
- ◇ Base Fuel Tank
- ◇ Starting batteries(Maintenance-Free & Watering-Free) with connective wires
- ◇ MCCB
- ◇ Oil Drain Valve
- ◇ Exhaust System(including until muffler)
- ◇ One set of fuel filter / oil filter / belt
- ◇ Documents

Options

- ◇ Daily Fuel Tank
- ◇ Battery Charger
- ◇ Engine Heater
- ◇ Alternator Heater
- ◇ Water Separator
- ◇ Permanent Magnet Generator(PMG)
- ◇ Rainproof Type
- ◇ Soundproof Type
- ◇ Trailer Type
- ◇ Paralleling System
- ◇ Remote Control Panel
- ◇ Automatic Transfer Switch
- ◇ Switch box
- ◇ Spare Parts

Dimension & Weight

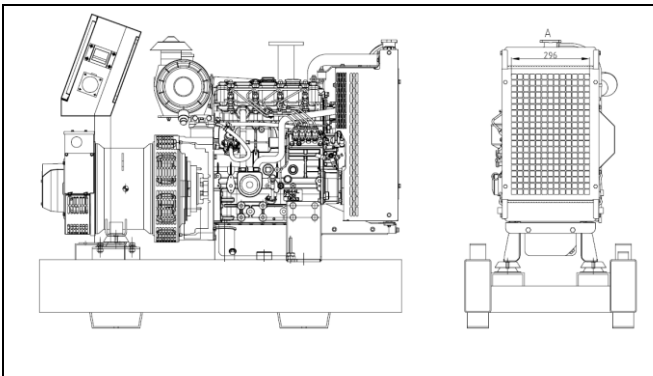

Open Type with Base Fuel Tank

Overall Size: 2150×940×1600 (mm)

Weight: 1250 kg

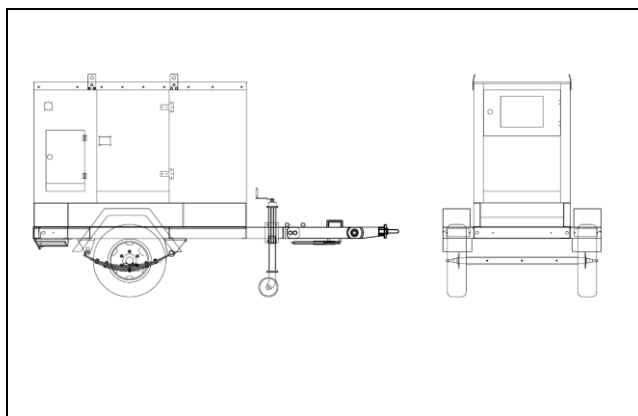

Soundproof Type

Overall Size: 2810×1140×1830 (mm)

Weight: 1920kg

Trailer Type

Overall Size: 3390×1720×2470 (mm)

Weight: 2560kg

Standard Control Panel



Baifa Standard Control Panel uses micro processing technique integrating digital, intelligent and network techniques which can carry out functions including auto start/stop, data measure, alarming. The controller uses LCD display, optional Chinese and English display interface with operation easy and reliable. It can be widely used in all types of generator automatic control system for compact structure, advanced circuits, simple connections and high reliability

Auto Module Control Panel



Auto Module Control Panel is the configuration for nobody on duty controlling generators. This kind of panel adopts auto module control system, with large LCD display to show the menu.

Features: MRS10-can receive remote output signal from ATS and realize auto start and stop of generators.

MRS16-can realize all functions of MRS10, add RS232 interface which can communicate with PC to realize remote operation.

AMF25-Auto Mains Failure controller, can realize all functions of MRS16, furthermore can detect ATS and control directly.